



**STRONG PARTNERS.
TOUGH TRUCKS.™**



HYSTER UT SERIES

ELECTRIC WALKIE PALLET TRUCK

P2.OUT / 2000KG

HYSTER.COM.AU

P2.OUT

THE HYSTER ELECTRIC WALKIE PALLET TRUCK P2.OUT COMBINES ERGONOMIC FEATURES AND RELIABLE PERFORMANCE WITH ENERGY EFFICIENT TECHNOLOGY. THE LOW-MAINTENANCE HELPS INCREASE PRODUCTIVITY AND REDUCE OPERATIONAL COSTS.

Productivity

- Advanced AC control system eliminates the motor brushes, which limits maintenance requirements
- Low skirting on main chassis
- Side battery roll-out system is very convenient to replace batteries
- Built-in pressure relief valve protects the trucks from overloading
- Emergency power disconnect switch
- Long handle reduces steering effort
- Emergency reversing system in handle
- Low speed switch in the handle
- Variable speed control
- Cold store configuration (option)

Optimum Structural Design

- Spring-loaded casters improve lateral stability on uneven floors and enhance truck performance and service life
- Formed heavy gauge steel provides maximum fork strength and longevity
- Pull rod design protects against bending
- Durable plastic covers

Serviceability

- CANbus technology reduces wiring complexity
- Low battery protection setting extends the battery life
- All pivot points have grease fittings and serviceable bushing, reducing component wear



**Handle (Standard)
(Left & Right Handed)**



**Entry roller for
easy operation**

SPECIFICATIONS AND DIMENSIONS

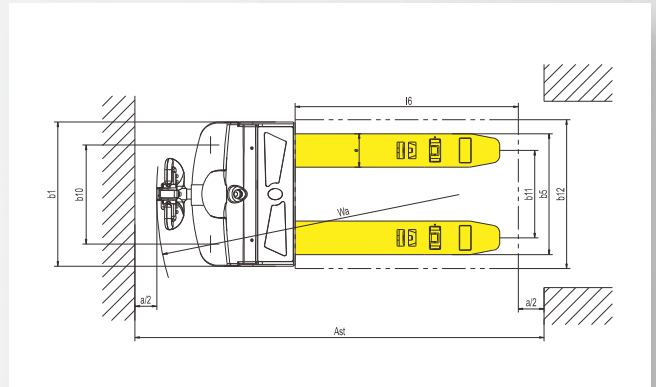
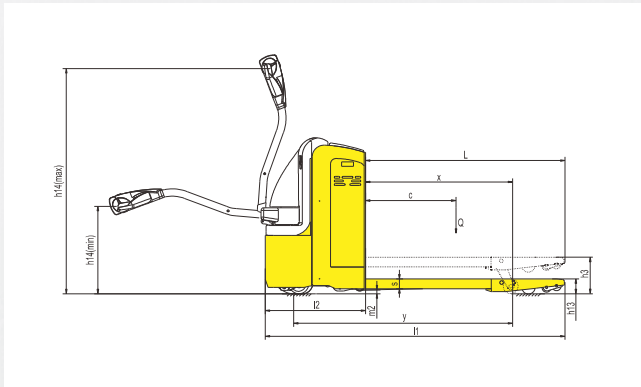

MODEL	MEASUREMENT	P2.OUT
Load capacity/rated load	Q (kg)	2000
Load centre distance	c (mm)	600
Load distance, centre of drive axle to fork	x (mm)	815/865/935
Fork height, lowered	h13 (mm)	82
Tyre size, front	mm	φ250x70
Tyre size, rear	mm	φ82x126 (98)
Additional wheels (dimensions)	mm	φ127x57
Wheels, number front rear (x=driven wheels)		1X+2/2 (4)
Max. Lift height	h3 (mm)	202
Height of tiller in drive position min./max.	h14 (mm)	780/1230
Overall length	l1 (mm)	1655/1705/1775
Length to face of forks	l2 (mm)	555
Overall width	b1 (mm)	775
Fork dimensions	s/e/l (mm)	54x180x1100/1150/1220
Width overall forks	b5 (mm)	520/550/650/685
Aisle width for pallets 1000x1200 crossways	Ast (mm)	2015/2065/2135
Aisle width for pallets 800x1200 lengthways	Ast (mm)	2115/2115/2135
Turning radius	Wa (mm)	1400/1450/1520
Travel speed, laden/unladen	Km/h	5.5/5.6
Battery voltage, nominal capacity K5	V/Ah	24/210
Battery weight	Kg	196
Battery box dimensions	mm	750x170x534
Service weight (with battery)	Kg	640-645

P2.OUT Power Plug Type

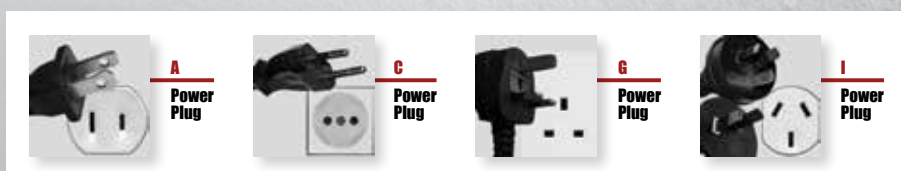



HYSTER® DEALERS

Contact your nearest Hyster® Dealership
by visiting www.hyster.com.au

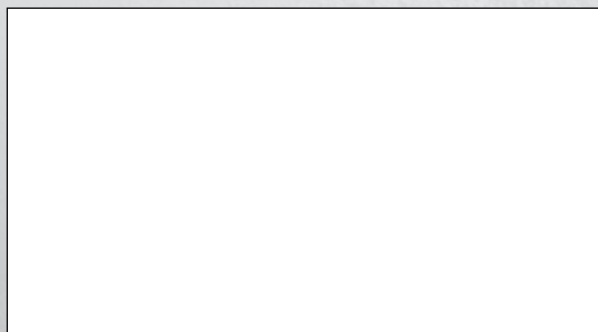

HYSTER PACIFIC

1 Bullecourt Avenue, Milperra NSW, Australia 2214

Tel: +61 (2) 9795 3800 Fax: +61 (2) 9792 8484

HYSTER ASIA

16 Tuas Avenue 20, Singapore 638827

Tel: +65 68633387 Fax: +65 68633349

hyster.com/pacific/en-au

hyster.com/asia/en-sg

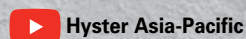
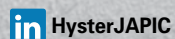
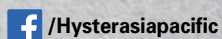

 is a Registered Trademark.

HYSTER is a Registered Trademark. STRONG PARTNERS. TOUGH TRUCKS. EZXCHANGE, HSM and VISTA are trademarks in the United States and certain other jurisdictions. © Hyster Asia Pacific 2019. All rights reserved. Printed in Australia. Specifications and details in this brochure are subject to change without prior notification. Please consult with your Hyster dealer for the most up to date information and to confirm exact capacities.

BR000067

HYSTER.COM.AU